

Analog, Mixed-Signal, and Radio-Frequency (RF) Electronic Design Laboratory

Electrical and Computer Engineering Department UNC Charlotte

Teaching and Research Faculty

(Please see faculty web pages for additional information)

David M. Binkley, Associate Professor <http://www.coe.uncc.edu/~dmbinkle/>

Arun Ravindran, Assistant Professor <http://www.coe.uncc.edu/~aravindr/>

Thomas P. Weldon, Associate Professor <http://wvs2.uncc.edu/tpw/>

Farid M. Tranjan, Professor <http://www.ece.uncc.edu/faculty/fac/tranjan/>

Overview

Semiconductor integrated circuits (chips) continually expand beyond digital computer and memory products, requiring analog, mixed-signal, and RF circuits. Analog circuits amplify and condition signals from sensors, actuators, and other devices that interface to the physical world. Mixed-signal circuits combine both analog and digital circuits to provide analog-to-digital, digital-to-analog, and other conversions between analog and digital circuits. RF circuits interface to antenna and wired systems to receive and transmit wireless and wired signals. Analog, mixed-signal, and RF circuits are required in cellular phone, wireless networking, broadband internet access, consumer products, medical imaging, and other high-growth applications. The Semiconductor Industry Association predicts over 60% of all semiconductor chips will contain analog, mixed-signal, or RF circuits.

The analog, mixed-signal, and RF electronic design group at UNC Charlotte is engaged in teaching and research to support the high demand for design professionals in North Carolina and the nation. North Carolina design companies include Analog Devices, RF Micro Devices, Maxim, Linear Technology, Texas Instruments, IBM, International Rectifier, Intersil, Semtech, Sony-Ericson, Rambus, Tality, Triad Semiconductor, and others. In addition to teaching, the group endeavors to enhance the state-of-the-art through novel research published in international conferences and journals.

Faculty

The analog, mixed-signal, and RF electronic design group consists of four, full-time faculty members active in electronic design research. The faculty has over 30 years of industry electronic design experience applied to medical imaging equipment, micropower battery-operated consumer products, and communications products. This assists the faculty in collaborating with and addressing the needs of North Carolina's considerable semiconductor industry. Additional faculty active in microelectronics device research teach core undergraduate and graduate analog electronics courses.

Research

Faculty in the analog, mixed-signal, and RF electronic design group are engaged in a wide variety of research projects involving design and testing. Technologies utilized include sub-micron bulk CMOS, silicon-on-insulator (SOI) CMOS for extreme temperatures and radiation, and organic and amorphous silicon processes for large-area, low-cost electronics.

Past research projects include

- DARPA neoCAD research resulting in a novel CAD tool for optimizing analog CMOS design (**Figure 1**)
- DARPA neoCAD, Agere, and NSF research for built-in self-testing (BIST) of mixed-signal systems, including fault simulation, assessment of circuit performance through loop-back testing, and transient supply-current testing
- Jet Propulsion Laboratory (JPL) research for micropower, low-noise CMOS electronics for neural implants (**Figure 2**)
- JPL research for micropower, low-noise, radiation-hardened SOI CMOS electronics for deep-space missions
- Duke energy research in electromagnetic compatibility for broadband-over-power-line (BPL) communications

Present research projects include

- Design methodologies for optimizing tradeoffs in gain, bandwidth, thermal noise, flicker noise, dc mismatch, distortion, and power consumption; one faculty member has completed the book, *Tradeoffs and Optimization in Analog CMOS Design*, John Wiley and Sons, June 2008.
- Micropower data converters utilizing advanced digital correction
- Design of analog circuits for low-cost, large-area electronics using organic and amorphous silicon FET's, previously supported by JPL
- Behavioral modeling of ZnO, thin-film FET devices and design of pixel driver and analog circuits, collaboration with AFRL
- Distortion reduction in RF receiving and transmitting electronics; one faculty member started MixSig Labs with Small Business Innovative Research (SBIR) funding to pursue commercializing this patented research (**Figure 3**)

Design Methodology CAD Tool

(Design optimization of analog CMOS gain,
bandwidth, noise, dc mismatch, etc.)

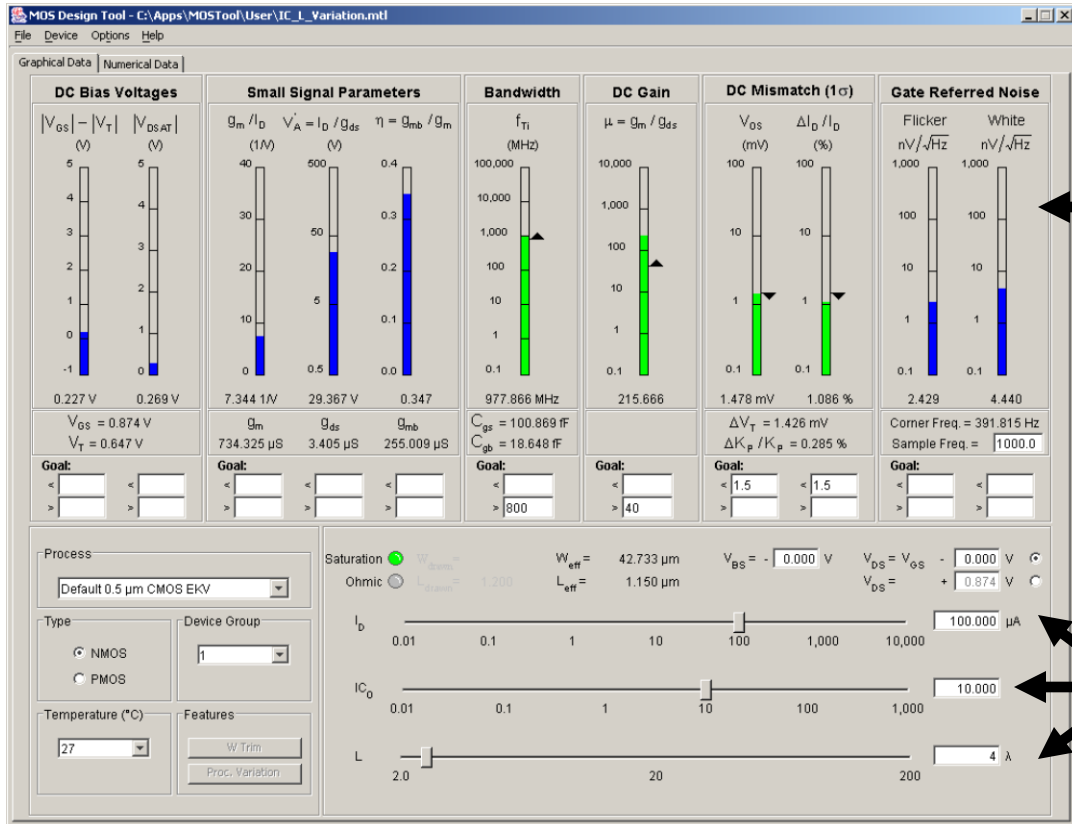

THEN,
Designer
observes
circuit
perform.
against
goals

FIRST,
Designer
explores
design
choices

Figure 1. Analog CMOS Optimization Tool (sponsored by DARPA neoCAD program). The designer selects MOS drain current, inversion coefficient (a numerical measure of inversion from weak through strong inversion), and channel length and observes the design tradeoffs of bias voltages, small-signal parameters, gain, bandwidth, dc mismatch, and noise. Circuit performance goals may be set where green bargraph displays denote goals are met while red bargraph displays denote goals are not met. This CAD tool minimizes trial-and-error SPICE simulations by providing design guidance and intuition. (Led by faculty member Dr. David Binkley).

Designer explores device current, inversion level, and length and observes tradeoffs in analog performance against goals.

“A CAD Methodology for Optimizing Transistor Current and Sizing in Analog CMOS Design,”
TCAD, 2003.

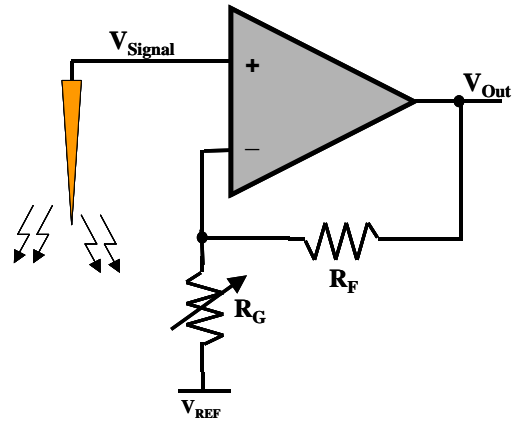
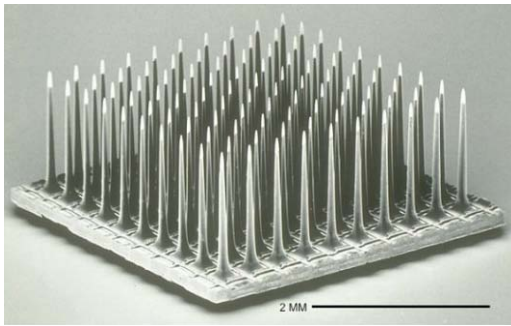

10 x 10 element MEMS probe (left) and variable-gain preamplifier architecture (right). Each neural probe is connected to a separate preamplifier, requiring micropower low-noise operation.

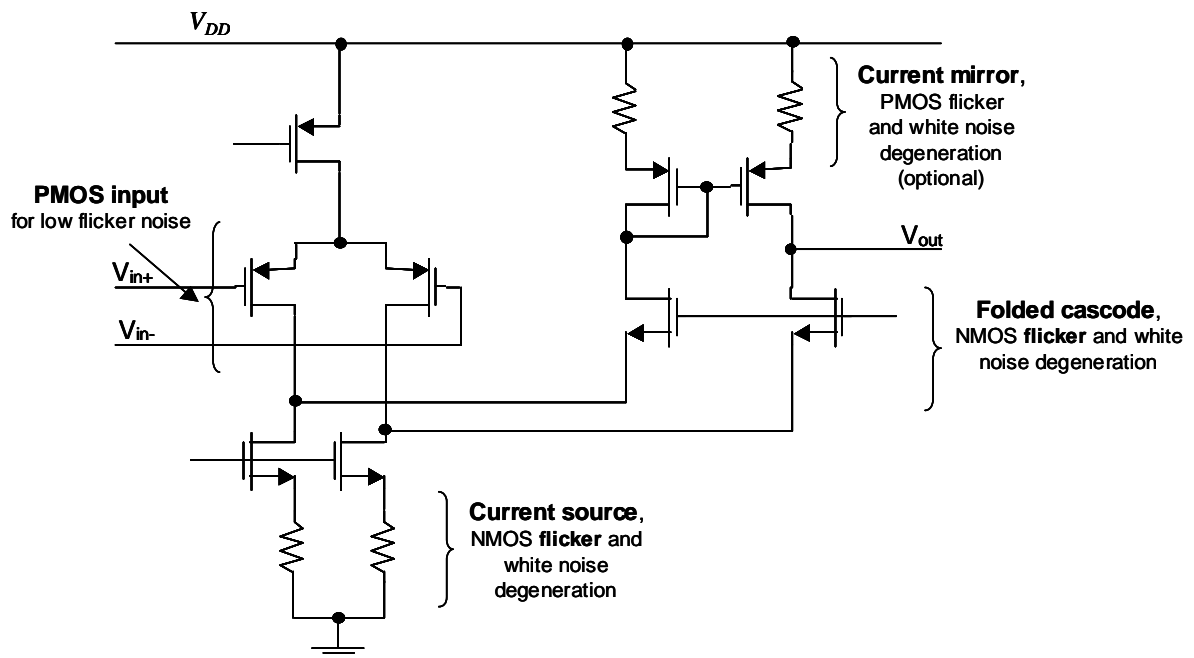

Preamplifier schematic notated with low-noise design techniques. Resistive noise degeneration ensures input pair devices dominate both thermal and low-frequency flicker noise. Input pair devices are operated in moderate inversion for high transconductance efficiency and minimum input-referred thermal noise voltage for the bias current of 1 μ A

Figure 2. Micropower, low-noise 0.35- μ m CMOS preamplifier for neural implant (sponsored by Jet Propulsion Laboratory). 100 preamplifiers amplify low-level voltage signals from a MEMS neural probe. Scientists at California Institute of Technology are conducting experiments with monkeys to process and decode signals corresponding to desired arm movements. If successful, this research could lead to human, thought-controlled artificial limbs. (Led by faculty member Dr. David Binkley).

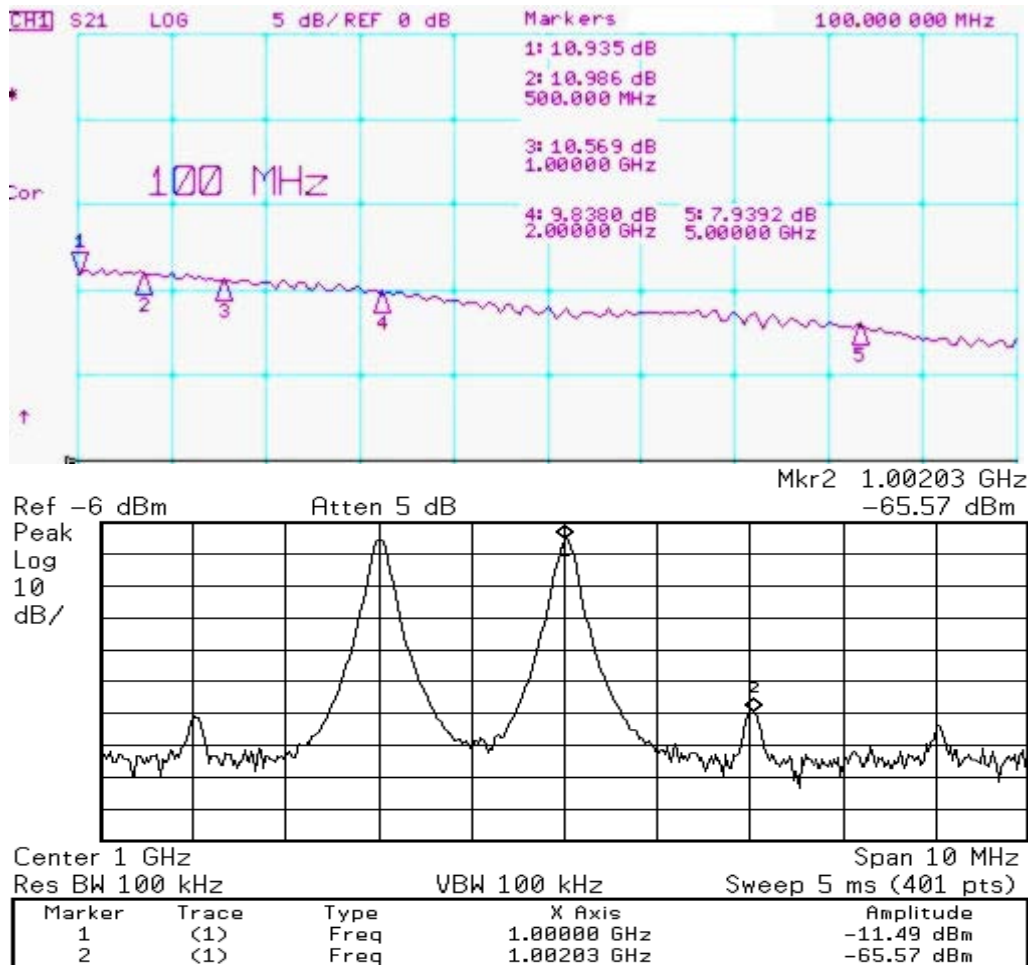
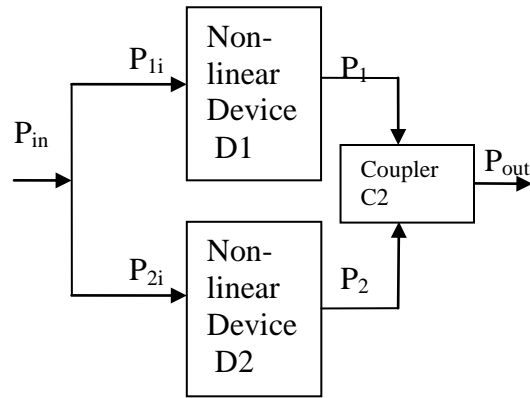
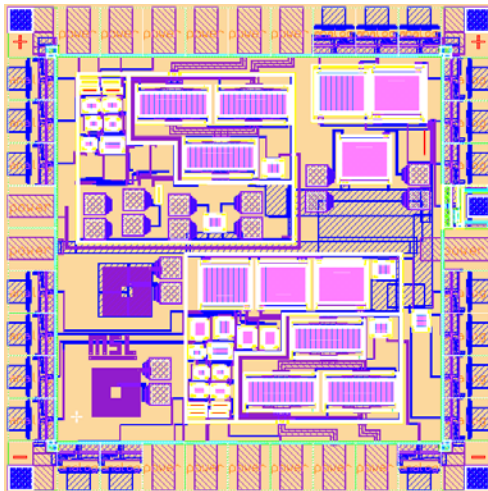

Figure 3. Experimental integrated circuits in linearization research (sponsored by MixSig Labs, Inc., and National Science Foundation). Upper left is layout of 0.18- μm CMOS, linearized RF integrated circuit; upper right is simplified block diagram of patented linearization method; middle is measured gain up to 5 GHz; bottom is two-tone linearized spectrum measured at 1 GHz. (Led by faculty member Dr. Tom Weldon).